

10+ YEARS OF PACKING MACHINE EXPERIENCE.

With advanced processing equipment, rich technical strength, manufacturing experience and support & service at whole process.

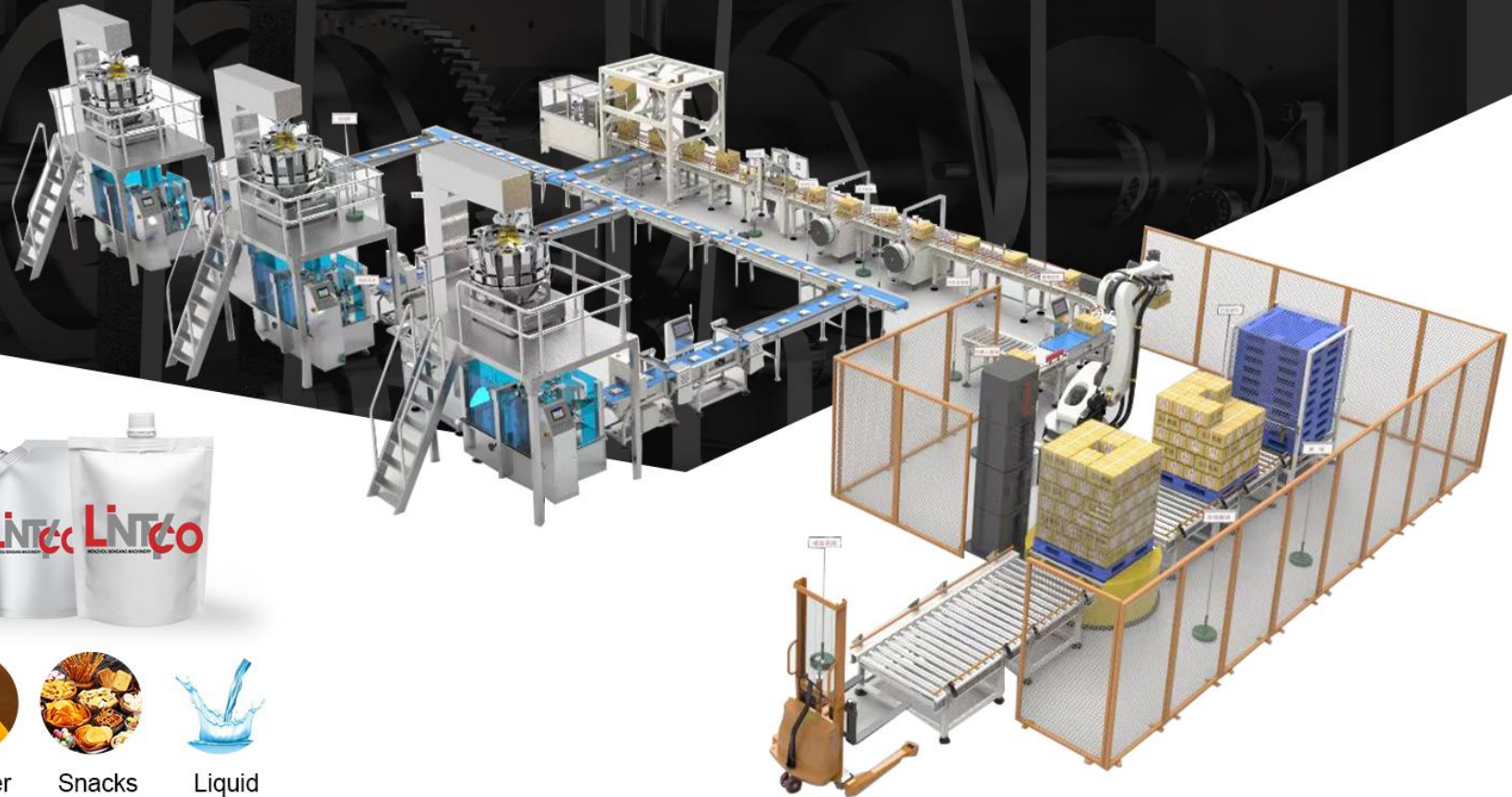
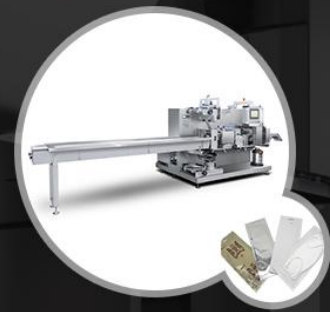

Frozen food Granule Pickle Powder Snacks Liquid

Address: NO.68 ZhouSong Road YuHai Street RuiAn City WenZhou

ZheJiang China

Web: www.bengangmachinery.com

Email: evelyn@lntyco.com

Phone: +8613868827095

温州本钢机械设备有限公司

WENZHOU BENGANG MACHINERY

全自动给袋式包装机 LTC8-200/260

Automatic Rotary Pre-made Pouch Packaging Machine



适用范围:

- 机器的包装范围广泛。根据不同的物料选择不同充填装置,可包装各种固体、颗粒、粉剂、液体、膏体等物料。
- 适用不同要求的预制袋。如平袋、自立袋、拉链袋、吸嘴袋、风琴袋、纸袋、铝箔袋、复合袋等。
- Wide application:It can choice of different types of filling machines to pack granules,solid, powder, liquid, paste, etc.
- It can adopt different types of pre-made pouches,such as Flat pouch, Stand-up pouch, Zipper pouch, Spout pouch, M gusset pouch, Paper pouch, Aluminium foil pouch, etc.

功能特点:

- 机器符合食品加工机械的卫生标准。机器上与物料和包装袋接触的零部件均采用符合食品卫生要求的材料加工304食品级不锈钢,保证食品的卫生和安全。
- 采用先进PLC配彩色POD(触摸屏),人机界面友好,操作方便。
- 主电机使用变频调速控制,生产中可根据实际需要在彩色触摸屏上在一定范围内随意设置频率。
- 机器标配自动检测装置,可以检测气压压力、温控仪故障、机器上袋情况、包装袋袋口有无打开,可判断机器状态、控制机器是否打码、充填装置是否进行充填,热封装置是否进行封口,从而避免浪费包材和原料,大大节约成本。
- Stainless steel 304 /other materials ensure sanitation and safety, meet the GMP standard.
- Adopts PLC with touch screen control system,the man-machine interface,easy to learn and operate.
- Frequency control system,packing speed can be adjusted within the range according to the actual situation.
- Standard with check device,which can check when there is without packaging materials or packing pouch is not open, the filling device and sealing device do not work to avoid wasting packing pouches and material.

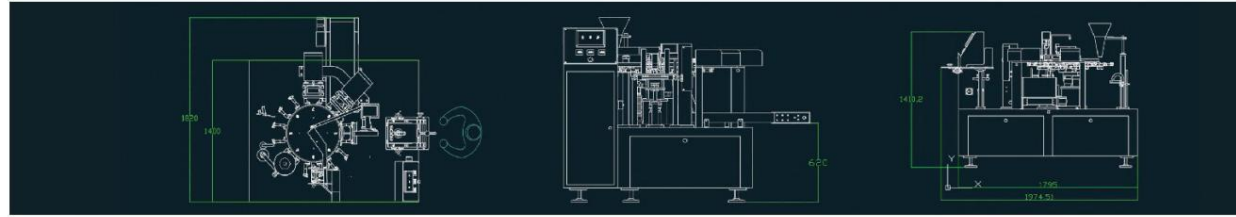

STAINLESS STEEL
MACHINE CLAMPS

机夹体采用不锈钢铸造工艺,一体成型,经久耐腐蚀。易清洗,易更换。袋宽自动调节。



CUSTOMIZED
PRE-MADE POUCH MAGAZINE

手轮调节袋宽和袋长。根据袋子类型定制袋仓结构。



SEALING & FORMING

两道热封。线封口,点封口,直纹封口,网纹封口供选择。温度可调,持久恒温。

技术参数 Main Technical Parameter

型号 Model	LTC8-200	LTC8-260
预制袋尺寸(毫米) Pre-made Pouch Size(mm)	W80-200 L80-400	W140-260 L100-400
包装速度(包/分) Packing Speed(pouch/min)	25-60	25-50
机器重量(千克) Machine Weight(kg)	1400	1500
包装范围(克) Filling Range(g)	10-1000(取决于产品类型 Depending on type of products)	
压缩空气消耗量 Air Consumption	≥0.6m ³ /min (压缩空气由用户自行提供 Supply by user)	
功率(千瓦) Power(kw)	2.5	
外形尺寸(毫米) Dimension(mm)	L1890*W1830*H1430	
标准8工位 8-station Working Process	1给袋 2打码 3上开袋 4落料 5预留 6预留 7热封 8整形输出 1Pouch Feeding 2Coding 3Pouch-top opening 4Filling 5Reserve 6Reserve 7Sealing 8Forming & Output	
可选装置 Addition Device	水平上袋,下开袋,开拉链,下振动,扫尘,关拉链,充氮气,打孔等 Horizontal Pouch Feeder,Pouch-bottom open,Zipper open,Pouch-bottom Vibration,Powder Deduster, Zipper Closed,Nitrogen Filling,Making Hole,etc.	

全自动大规格给袋式包装机LTC8-300

Automatic Rotary Pre-made Pouch Packaging Machine

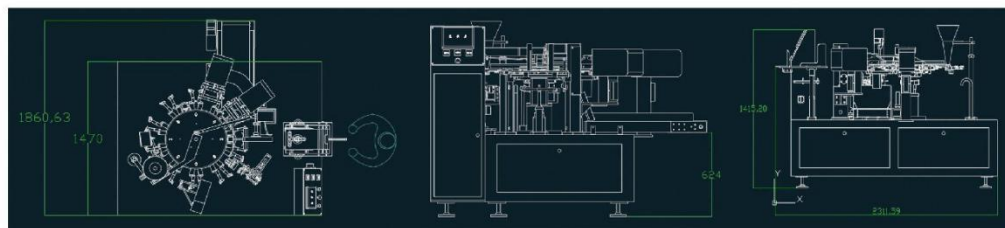
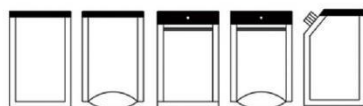
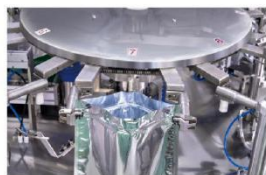

技术参数 Main Technical Parameter

型号 Model	LTC8-300
预制袋尺寸(毫米) Pre-made Pouch Size(mm)	W180-300 L100-400
包装速度(包/分) Packing Speed(pouch/min)	10-35
机器重量(千克) Machine Weight(kg)	1700
包装范围(克) Filling Range(g)	10-2500 (取决于产品类型 Depending on type of products)
压缩空气消耗量 Air Consumption	≥0.6m ³ /min (压缩空气由用户自行提供 Supply by user)
功率(千瓦) Power(kw)	3
外形尺寸(毫米) Dimension(mm)	L2290*W1500*H1420

全自动10工位给袋式包装机LTC10-200

Automatic Rotary Pre-made Pouch Packaging Machine

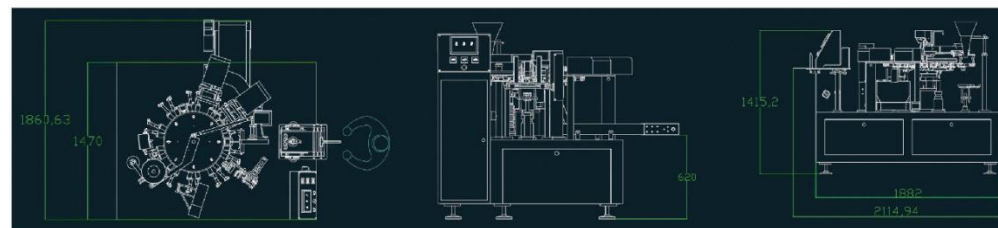
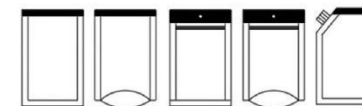

技术参数 Main Technical Parameter

型号 Model	LTC10-200
预制袋尺寸(毫米) Pre-made Pouch Size(mm)	W100-200 L100-400
包装速度(包/分) Packing Speed(pouch/min)	20-80
机器重量(千克) Machine Weight(kg)	1700
包装范围(克) Filling Range(g)	10-1000 (取决于产品类型 Depending on type of products)
压缩空气消耗量 Air Consumption	≥0.6m ³ /min (压缩空气由用户自行提供 Supply by user)
功率(千瓦) Power(kw)	2.5
外形尺寸(毫米) Dimension(mm)	L2090*W1500*H1420

全自动给袋式颗粒包装流水线

Automatic Rotary Pre-made Pouch Granule Weigh-Fill-Seal Production Line

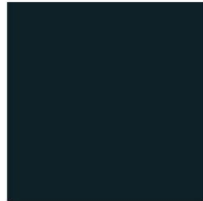

物料提升机
MATERIAL CONVEYOR

微电脑组合秤
MULTIHEAD WEIGHER



适用范围:

- 机器的包装范围广泛, 适用于块状物料和颗粒。
- 块状物料类: 鱼仔、糖果、红枣、麦片、花生、日用品、膨化食品等。
- 颗粒类: 颗粒状药品、胶囊、种子、咖啡豆、果仁、饲料、五金等。
- Wide application: It adopt different types of block material and granule.
- Block material: fish boll, candy, red jujube, cereal, peanut, daily necessities, puffed food, etc.
- Granules: granular drugs, capsules, seeds, coffee bean, nuts, fertilizers, hardware, etc.

功能特点:

- 颗粒包装流水线主要由Z型提升机, 多头秤, 工作平台和给袋式包装机组成。
- 包装速度快, 性能稳定。
- 采用先进PLC配彩色POD(触摸屏), 人机界面友好, 操作方便。
- 适用预制袋, 封口质量好, 可提升产品档次。
- Granule weigh-fill-seal production line consists of conveyor, multihead weigher, working platform and rotary pre-made pouch packing machine.
- High speed, stable performance.
- Adopts PLC with touch screen control system, the man-machine interface, easy to learn and operate.
- Mchine adopt pre-made pouches, good sealing quality to improve grade



技术参数 Main Technical Parameter

型号 Model	LTC8-200	LTC8-260	LTC10-200	LTC8-300
预制袋尺寸(毫米) Pre-made Pouch Size(mm)	W80-200 L80-400	W140-260 L100-400	W100-200 L100-400	W180-300 L100-400
包装速度(包/分) Packing Speed(pouch/min)	25-55	25-50	20-80	10-35
机器重量(千克) Machine Weight(kg)	1400	1500	1700	1700
包装范围(克) Filling Range(g)	10-1000(取决于产品类型 Depending on type of products)			10-2500
压缩空气消耗量 Air Consumption	≥0.6m³/min (压缩空气由用户自行提供 Supply by user)			

全自动给袋式粉剂包装流水线

Automatic Rotary Pre-made Pouch Powder Weigh-Fill-Seal Production Line



适用范围:

- 机器的包装范围广泛, 适用粉剂物料。
- 粉剂: 奶粉、调味品、可可粉、农药、洗衣粉、面粉等。
- Wide application: It adopt different types of powder.
- Powder type: milk powder, seasoning, coco milk, pesticide, washing powder, flour, etc.

功能特点:

- 粉剂包装流水线主要由给袋式包装机, 螺杆秤, 螺杆提升机组成。
- 包装速度快, 性能稳定。
- 采用先进PLC配彩色POD(触摸屏), 人机界面友好, 操作方便。
- 适用预制袋, 封口质量好, 可提升产品档次。
- Powder material packing system consists of rotary premade pouch packing machine, auger filler and auger conveyor.
- Adopts PLC with touch screen control system, the man-machine interface, easy to learn and operate.
- Machine adopt pre-made pouches, good sealing quality to improve grade of product.



技术参数 Main Technical Parameter

型号 Model	LTC8-200	LTC8-260	LTC10-200	LTC8-300
预制袋尺寸(毫米) Pre-made Pouch Size(mm)	W80-200 L80-400	W140-260 L100-400	W100-200 L100-400	W200-300 L100-400
包装速度(包/分) Packing Speed(pouch/min)	25-50	25-45	20-80	10-35
机器重量(千克) Machine Weight(kg)	1400	1500	1700	1700
包装范围(克) Filling Range(g)	10-1000(取决于产品类型 Depending on type of products)			10-2500
压缩空气消耗量 Air Consumption	≥0.6m ³ /min (压缩空气由用户自行提供 Supply by user)			

全自动给袋式液体包装流水线

Automatic Rotary Pre-made Pouch Liquid Weigh-Fill-Seal Production Line



适用范围:

- 机器的包装范围广泛, 适用液体膏状物料。
- 液体/膏体: 洗手液、酱油、饮料、果汁、花生酱、辣椒酱、火锅酱等。
- Wide application: It adopt different types of liquid and paste.
- Liquid/paste type: hand washing gel, soy, beverage, peanut butter, chili sauce, hotpot sauce, etc.

功能特点:

- 液体包装流水线主要由给袋式包装机, 液体灌装机组成。
- 防水装置易清洁。
- 采用先进PLC配彩色POD(触摸屏), 人机界面友好, 操作方便。
- 适用预制袋, 封口质量好, 可提升产品档次。
- Liquid material packing system consists of rotary premade pouch packing machine and liquid filling machine.
- Waterproof system makes cleaning easier.
- Adopts PLC with touch screen control system, the man-machine interface, easy to learn and operate.
- Machine adopt pre-made pouches, good sealing quality to improve grade of product.



技术参数 Main Technical Parameter

型号 Model	LTC8-200	LTC8-260	LTC10-200	LTC8-300
预制袋尺寸(毫米) Pre-made Pouch Size(mm)	W80-200 L80-400	W140-260 L100-400	W100-200 L100-400	W200-300 L100-400
包装速度(包/分) Packing Speed(pouch/min)	25-50	25-45	20-80	10-35
机器重量(千克) Machine Weight(kg)	1400	1500	1700	1700
包装范围(克) Filling Range(g)	10-1000(取决于产品类型 Depending on type of products)			10-2500
压缩空气消耗量 Air Consumption	≥0.6m ³ /min (压缩空气由用户自行提供 Supply by user)			

全自动给袋式真空包装机LTC130V/200V

Automatic Rotary Pre-made Pouch Vacuum Packaging Machine

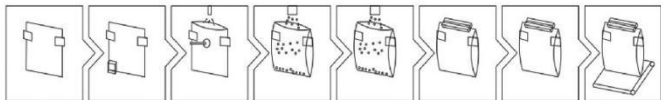

取袋 Pouch Feeding 喷码(可选) Coding 开袋 Pouch Opening 填充1 Filling 1 填充2 Filling 2 转接 Transfer 真空热封 Sealing 整形输出成品 Forming and Output

适用范围:

- 机器的包装范围广泛。根据不同的物料选择不同充填装置,就可包装各种固体、颗粒、粉剂、液体、酱体等物料。
- 适用不同要求的预制袋。如平袋、自立袋、拉链袋、吸嘴袋、风琴袋、纸袋、铝箔袋、复合袋等。
- Wide application:It can choice of different types of filling machines to pack granules,solid, powder, liquid, paste, etc.
- It can adopt different types of pre-made pouches,such as Flat pouch, Stand-up pouch, Zipper pouch, Spout pouch, M gusset pouch, Paper pouch, Aluminium foil pouch, etc.

功能特点:

- 给袋式真空包装机由两种旋转式机体组成(分别为充填系统和真空系统),加料系统柔性转动,真空系统为连续式旋转运动。
- 机器上与物料和包装袋接触的零部件均采用符合食品卫生要求的材料加工304食品级不锈钢,保证食品的卫生和安全。
- 采用先进PLC配彩色POD(触摸屏),人机界面友好,操作方便。
- 机器标配自动检测装置,可以检测气压压力、温控仪故障、机器上袋情况、包装袋袋口有无打开,可判断机器状态、控制机器是否打码、充填装置是否进行充填,热封装置是否进行封口,从而避免浪费包材和原料,大大节约成本。
- Rotary pre-made pouch vacuum packing machine has two parts:the filling system rotates intermittently to fill the product easily while vacuum system rotates continuously to enable smooth running.
- Stainless steel 304 /other materials ensure sanitation and safety, meet the GMP standard.
- Adopts PLC with touch screen control system, the man-machine interface,easy to learn and operate.
- Standard with check device, which can check when there is without packaging materials or packing pouch is not open, the filling device and sealing device do not work to avoid wasting packing pouches and material.



技术参数 Main Technical Parameter

型号 Model	LTC130V	LTC200V
预制袋尺寸(毫米) Pre-made Pouch Size(mm)	W55-130 L80-180	W120-200 L150-300
包装速度(包/分) Packing Speed(pouch/min)	40-80	10-50
机器重量(千克) Machine Weight(kg)	2000	3000
包装范围(克) Filling Range(g)	10-500(取决于产品类型 Depending on type of products)	
压缩空气消耗量 Air Consumption	≥0.6m³/min (压缩空气由用户自行提供 Supply by user)	
功率(千瓦) Power(kw)	2.5	5.5
外形尺寸(毫米) Dimension(mm)	L2100*W1400*H1700	L2600*W1900*H1700
标准8工位 8-station Working Process	1给袋 2打码 3上开袋 4灌料 5预留 6预留 7真空热封 8整形输出 1Pouch Feeding 2Coding 3Pouch-top opening 4Filling 5Reserve 6Reserve 7Vacuum & Sealing 8Forming & Output	

全自动高速水平式四边封包装机

Full servo high speed horizontal 4 sides seal pouch form fill seal packing machine

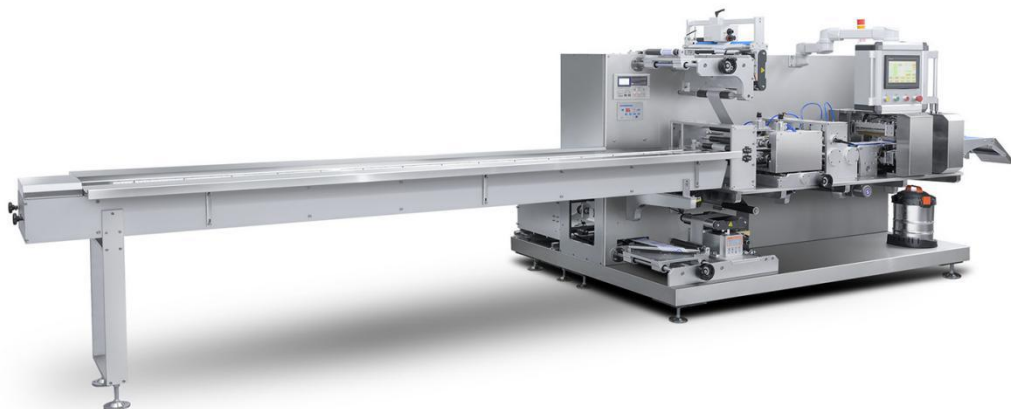

下料输送平台
Material inputting conveyor

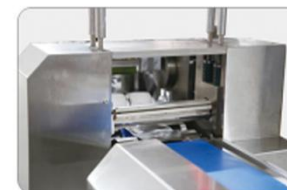

旋转切断刀
Rotary cutter



色标跟踪部件
Eye mark tracking



自动下料器
Auto feeder



中封部件以及激光检测
Both sides sealing and laser detection



废边分切及往复易撕口部分
Both sides cutting and easy tear making

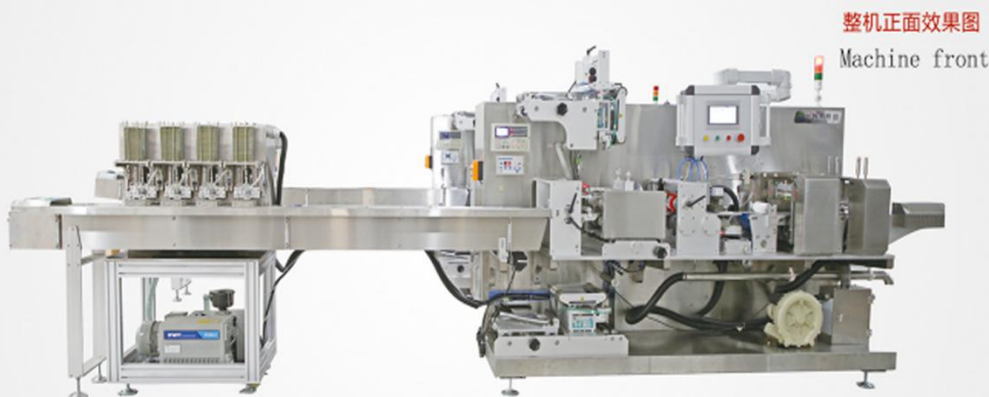

整机正面效果图
Machine front



整机背面效果图
Machine back

技术参数 Main Technical Parameter

Model	BG400 full servo horizontal 4 sides seal pouch form fill seal packing machine
Packing speed	80-180 bag/min
Packing material	ET+OPP,BOPP,CPP,PET+AL,and laminated film
Bag forming range	100-280mm(L), 60-160mm(W), 1-10mm(H)
Max. Dia. and width of film	φ400mm/400mm
Compressed air	0.4-0.8m³ supply by user
Power supply	10-13KW, 380V 50HZ 3P
Machine weight and size	2000KGS/5680mm(L)*1611mm(W)*1900mm(H)

全自动立式制袋包装机

Automatic Vertical Pouch Packaging Machine



适用范围:

- 机器的包装范围广泛。适用颗粒、粉剂、液体膏状物料。
- Wide application: It adopt different types of granule, powder, liquid and paste.

功能特点:

- 配备安全防护, 符合企业安全管理要求。
- 采用智能温控器, 温度控制准备, 保证封口美观, 平整。
- 采用PLC伺服系统, 气动控制系统, 超大显示触摸屏, 提高了整机的控制精度, 可靠性和智能化程度。
- 设有故障显示系统, 可及时排除故障。
- Equipped with safety protection, in line with enterprise safety management requirements.
- Use intelligent temperature controller to have accurate temperature, which ensures the artistic and neat seal.
- Use PLC servo system and pneumatic control system and super touch screen to compose the drive control center which max, the whole machine's control precision, reliability and intelligentized level.
- Equipped with fault display system, troubleshooting can be timely.

技术参数 Main Technical Parameter

型号 Model	LTC320	LTC420	LTC520	LTC620
制袋尺寸(毫米) Making Pouch Size(mm)	W50-150 L60-250	W60-200 L60-300	W60-250 L80-350	W100-300 L100-400
包装速度(包/分) Packing Speed(pouch/min)	40-100	30-80		30-70
电源 Power	220V, 50/60Hz, 3.0Kw			
耗气量(立方米/分) Air Consumption(m ³ /min)	0.3			
机器重量(千克) Machine Weight(kg)	300	350		400
机器尺寸 长*宽*高(毫米) Machine Dimension L*W*H(mm)	1400*1000*1200	1650*1100*1500	1650*1200*1600	1800*1300*1750

全自动糖果枕式包装机BG1200

Automatic candy pillow packing machine



技术参数 Main Technical Parameter

Max. Capacity	最大生产能力	1200粒/分
Packing Spec.	包装物规格	长 (Length) 12-40mm 宽 (Width) 12-30mm 高 (Height) 5-18mm
Length of Finished bag	成形袋长	50-80mm
Candy Shape	糖块形状	正方形、椭圆形、扁圆形、球形、梅花形等 Square, Ellipse, Oblate, Globular, Plum Blossom-Shaped
Gross Power	总功率	4Kw
Overall Dimensions	外形尺寸	2500*1350*1720mm
Gross Weight	总重量	1400kg
Power Supply	电源	220V 50Hz
Packing Material	包装材料	OPP、CPP、PET镀铝膜、铝塑膜、纸塑、纸胶等单层多层等可热封材料 建议使用外层PET厚度0.013mm, 内层CPP厚度0.023~0.027mm, 复合低温膜 OPP、CPP、PET Metallized film, Al-plastic film, Paper-rubber complex Suggest to used wrapping film with material of PET13/ CPP23-27

Note: We can design and manufacture according to customer's special needs. 注: 用户如有特殊规格, 本公司可另行设计制造。

全自动理料枕式包装机BG660

Fully Automatic pillow type packing machine

This machine is suitable for packing chocolate, wafer, confectionery, coated product and so on.

适用于巧克力、威化、膨化、米果、面包、蛋糕、瑞士卷、糖果等及其涂层制品的包装。

- 1 This machine is driven by servo motors, which helps achieve more convenient operation and easier maintainance
- 2 This machine adopts wrapping film auto splice device, which helps the machine achieves splicing of film without stopping machine
- 3 It adopts 304 stainless steel cover
- 4 Famous brand of control system, makes sure of stable working of machine
- 5 Touch screen and plc help operating of machine more intuitive.
- 6 Adopts water chiller for chocolate products, to prevent chocolates from being melt during packing.
- 7 To ensure fast packing speed, our machine uses 3sets of middle seal wheels together with preheating.
- 8 The machine is equipped with remote control system, which makes solving of program problems much easier.

Max.Production Capacity	最大生产能力	1200包/分 (bags/min)	
Packing Range	Length of bag	包装范围 袋长	55-200mm
	Width	包装范围 袋宽 (袋长由切刀数决定)	15-60mm
	Height	高度	5-30mm
Max.Dia.of Film	包装膜最大直径	390mm	
Max.Width of Film	包装膜最大宽度	300mm	
Gross Power	总功率	9.6kw	
Power Supply	电源	380V 50Hz	
Gross Weight	总重量	1600kg	
Overall Dimension	外形尺寸	9800x1000x1700mm	
Packing Material	包装材料	OPP、CPP、PET镀铝膜、铝塑膜、纸塑、纸胶等单层多层等可热封材料 建议使用外层PET厚度0.013mm,内层CPP厚度0.023~0.027mm,复合低温膜 OPP、CPP、PET Metallized film, Al-plastic film, Paper-rubber complex Suggest to used wrapping film with material of PET13/CPP23-27	

Note: We can design and manufacture according to customer's special needs.
注: 用户如有特殊规格, 本公司可另行设计制造。



配套设施 Auxiliary Equipment



微电脑组合秤
MULTIHEAD WEIGHER



液体灌装机
LIQUID FILLING MACHINE



贴标机
LABELING MACHINE



对角贴标机
DIAGONAL LABELING MACHINE



工作平台
WORKING PLATFORM



膏体灌装机
PASTE FILLING MACHINE



热熔胶机
HOT MELT GLUER



喷码机
INK-JET PRINTER



粉剂螺杆计量秤
POWDER AUGER FILLER



真空吸尘器
VACUUM DUST COLLECTOR



重量选别秤
CHECK WEIGHER



金属检测机
METAL DETECTOR

配套输送设备 Conveying Equipment



Z型提升机
Z TYPE CONVEYOR



振动斜坡提升机
VIBRATING SLOPE CONVEYOR



大倾角提升机
INCLINED BELT CONVEYOR



碗式提升机
BOWL TYPE CONVEYOR



单斗提升机
SINGLE BUCKET CONVEYOR



真空上料机
VACUUM CONVEYOR



载重皮带输送
LOADING BELT CONVEYOR



皮带输送
BELT CONVEYOR



粉剂螺杆提升机
POWDER AUGER CONVEYOR



网带输送
MESH BELT CONVEYOR